

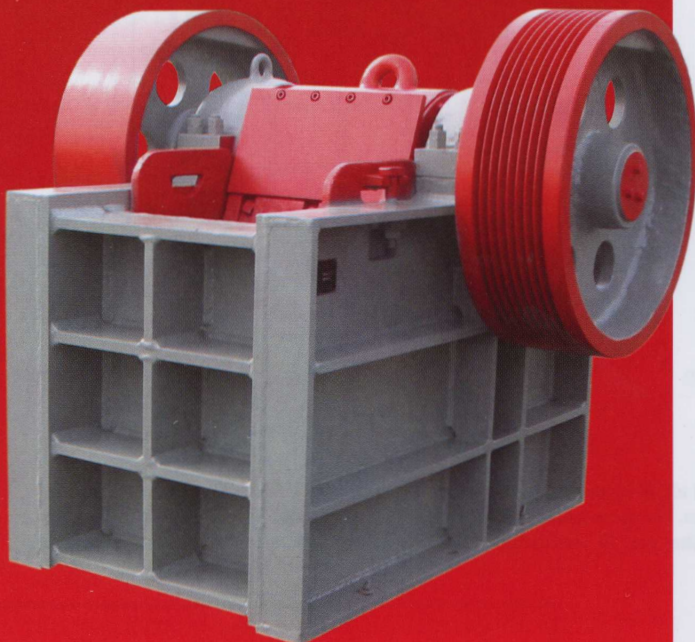

PE

1624 Jaw Crusher



The Affordable Alternative in New Crushing Equipment

Standard Features

- Single wall main frame of stress relieved steel
- Open back for easy maintenance
- All working parts lubricated for moisture and dirt protection
- Reversible manganese jaw dies for maximum wear life
- Spherical, self-aligning roller bearings
- Isolated, close running annular/labyrinth seals protect bearings from dust and water
- Removable pitman/bearing assembly for maintenance ease
- Hydraulic or manual shim adjustment
- Heavy duty, cast steel pitman with machined barrel
- Machined pitman face for full swing jaw die support
- Smooth running flywheels with compression ring fastening arrangement

Optional Features

- Electric motor
- Drive sheave and bushing



The Affordable Alternative in New Crushing Equipment

Specifications

Feed opening	16" × 24"
Discharge setting	1-1/2" to 4"
Maximum feed size	14"
Production range	20 to 80 TPH
Discharge setting	
1-1/2"	20 to 35 TPH
2"	30 to 50 TPH
2-1/2"	35 to 60 TPH
3"	45 to 70 TPH
3-1/2"	55 to 75 TPH
4"	60 to 80 TPH
Required horsepower	50 HP
Rotor speed	275 RPM

Weights (LBS)	
Crusher	14,300
Flywheel	1,200
Swing jaw die	500
Fixed jaw die	475
Standard part dimensions (inches)	
Fixed jaw length	38
Swing jaw length	39
Bearing information	
Size	190 × 400 × 132 mm
Bearing No.	22338CC/W33

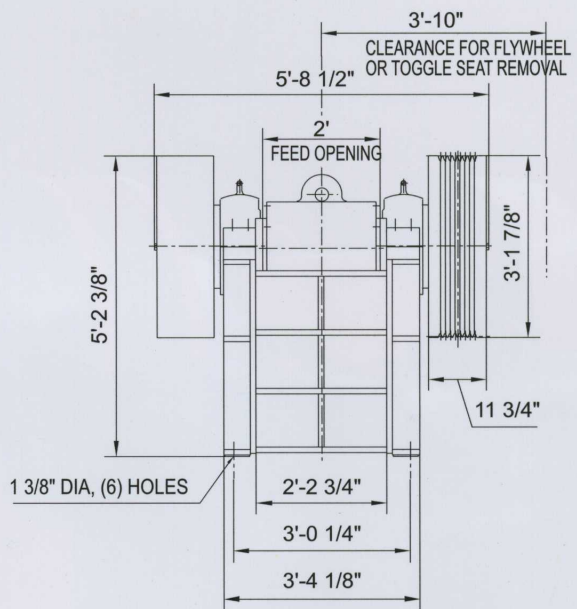
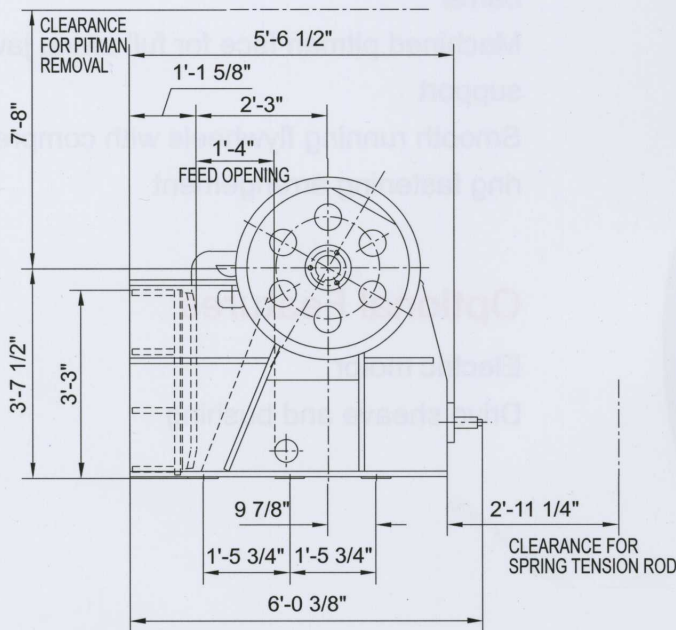

Note: Because of the nature of jaw crushers, it is not possible to produce a product all of which will pass a screen opening equivalent to the discharge setting. Oversize should be expected, and will fluctuate depending on the rock characteristics. For close settings, all undersize material should be screened off to increase the effectiveness of the jaw and to reduce wear on the jaw dies. Although the crusher may be configured to have a different discharge opening than indicated above, this crusher model is not designed to operate at other settings.



Jaw Crusher Capacity in Tons

Closed Side Setting	10 x 30	10 x 39	10 x 47	12 x 51	10 x 16	16 x 24	18 x 42	20 x 30	24 x 36	30 x 42	32 x 42	36 x 48
3/4" 19mm	10~15	15~20	20~30		5							
1" 25.4mm	15~25	20~30	30~40	50~70	15							
1-1/2" 38.1mm	25~35	30~40	40~50	55~80	15~20	20~35						
2" 50.8mm	35~40	40~50	50~60	55~90	20~25	30~50		50~65				
2-1/2" 62.5mm	40~45	50~55	60~70	75~100	25~30	35~60		65~80				
3" 76.2mm	45~50	55~60	70~80	85~110		45~70		80~95	70~90	100~125		
3-1/2" 88.9mm				100~130		55~75	60~75	95~110	80~110	125~150		
4" 101.6mm						60~80	70~90	110~120	90~120	150~175	150~175	280~340
4-1/2" 114.3mm							80~105		110~140	175~200	175~200	300~350
5" 127.0mm							90~120		120~170	200~225	200~225	320~370
6" 152.4mm										225~250	225~250	360~400
7" 177.8mm											250~275	380~420
8" 203.2mm											275~300	400~450

All capacities are based on 100 lbs. per cubic ft. weight of rock. Tonnage may vary depending on size of feed, rate of feed, peropare operation and operating conditions, breaking characteristics and compression strength of rock samples. Type and condition of jaw face and horsepower used can also effect production capacity.